

PANEL RADIATOR

Submittal

PR2-2

Specification

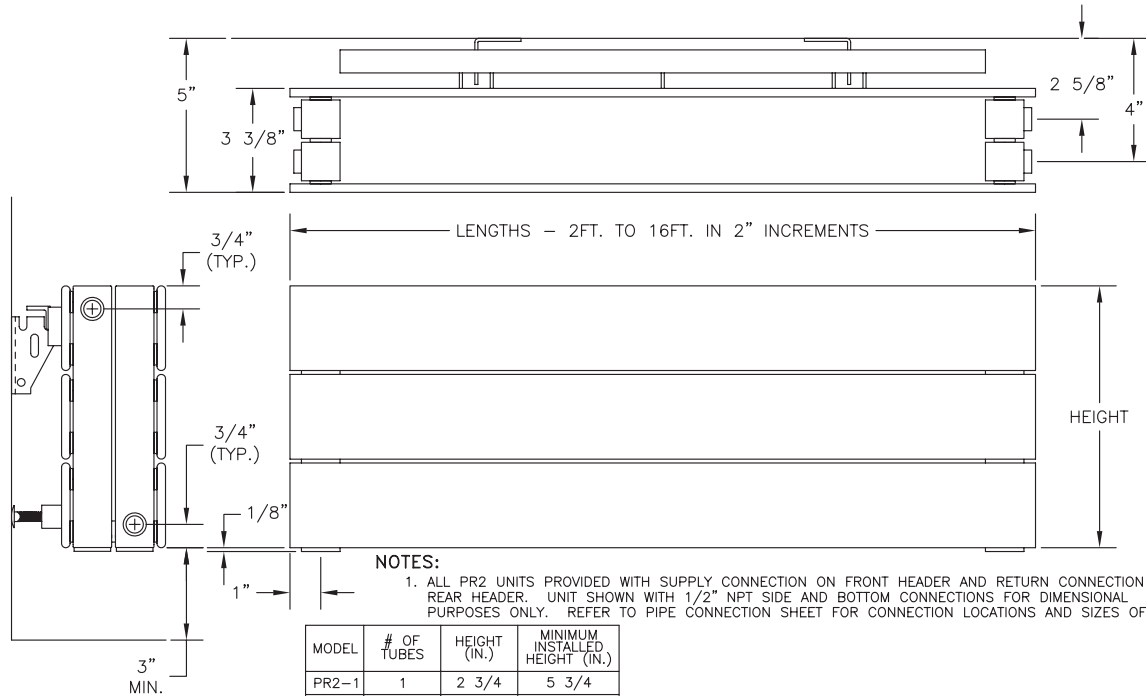

MODEL	# OF TUBES	HEIGHT (IN.)	MINIMUM INSTALLED HEIGHT (IN.)
PR2-1	1	2 3/4	5 3/4
PR2-2	2	5 3/4	8 3/4
PR2-3	3	8 5/8	11 5/8
PR2-4	4	11 1/2	14 1/2
PR2-5	5	14 3/8	17 3/8
PR2-6	6	17 1/4	20 1/4
PR2-7	7	20 1/4	23 1/4
PR2-8	8	23 1/8	26 1/8
PR2-9	9	26 1/8	29 1/8
PR2-10	10	29	32

CAT-75573B

MODEL TYPE	BTU/FT/HR @ LISTED AWT & 65°F EAT								
	215°F	190°F	180°F	170°F	160°F	150°F	140°F	130°F	120°F
PR2 01	480	374	331	293	254	216	192	158	125
PR2 02	862	672	595	526	457	388	345	284	224
PR2 03	1274	994	879	777	675	573	510	420	331
PR2 04	1680	1310	1159	1025	890	756	672	554	437
PR2 05	2096	1635	1446	1279	1111	943	838	692	545
PR2 06	2524	1969	1742	1540	1338	1136	1010	833	656
PR2 07	2960	2309	2042	1806	1569	1332	1184	977	770
PR2 08	3392	2646	2340	2069	1798	1526	1357	1119	882
PR2 09	3820	2980	2636	2330	2025	1719	1528	1261	993
PR2 10	4260	3323	2939	2599	2258	1917	1704	1406	1108



STERLING

COMMERCIAL HYDRONIC PRODUCTS

260 North Elm St., Westfield, MA 01085

(413) 564-5535 Fax: (413) 562-8437

www.sterlingheat.com

PROJECT: _____ DATE: _____

LOCATION: _____

ARCHITECT: _____

ENGINEER: _____

CONTRACTOR: _____

PO NUMBER: _____

TYPICAL WALL MOUNTED INSTALLATION

WALL MOUNTING – TYPICAL INSTALLATION
WALL MOUNTING: PR, PR2, PR2F

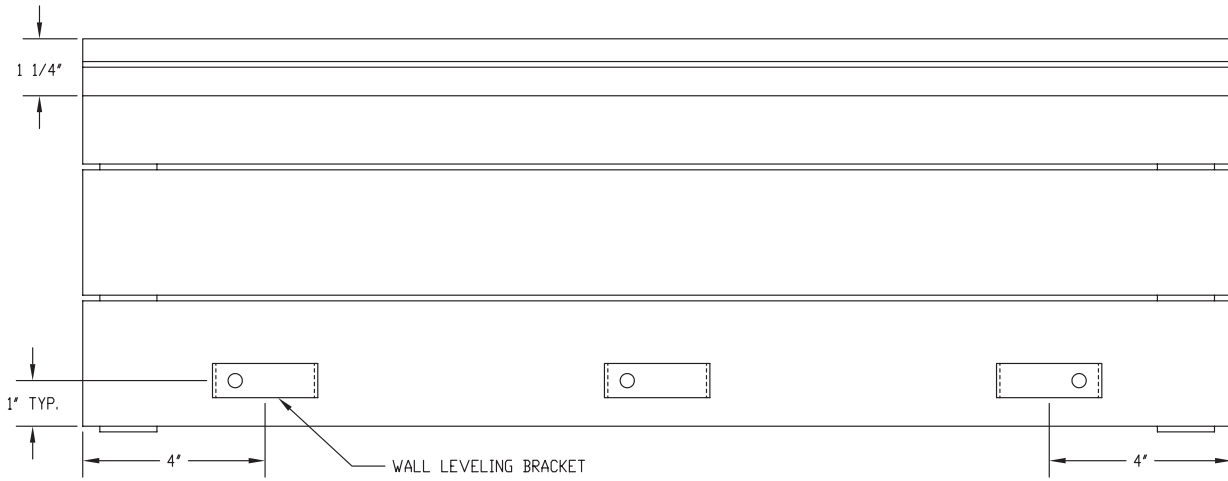

TYPICAL LEVELING BRACKET INSTALLATION (BACKVIEW)

PANEL LENGTH	QTY. OF BRACKETS
24' - 60'	2 PCS
62' - 138'	3 PCS
140' - 236'	4 PCS
238' - 240'	5 PCS

A LEVELING BOLT IS SUPPLIED FOR EACH BRACKET

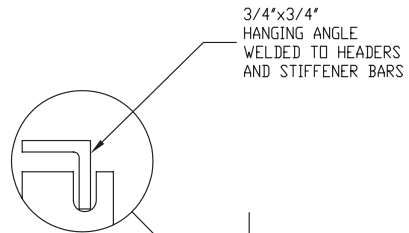

3/4"x3/4"
HANGING ANGLE
WELDED TO HEADERS
AND STIFFENER BARS

TYPICAL WALL MOUNTING BRACKET INSTALLATION

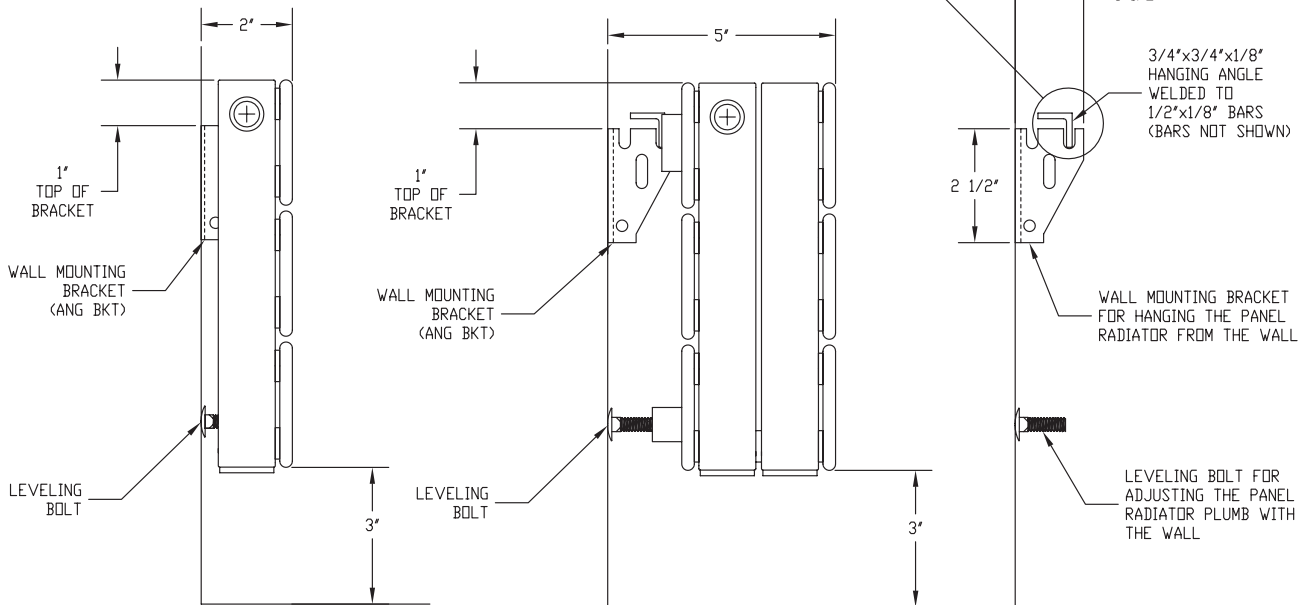

TYPICAL FREE STANDING PEDESTAL MOUNTED INSTALLATION

PEDESTAL MOUNTING FREE STANDING FLOOR MOUNT PR2, PR2F & PR3F

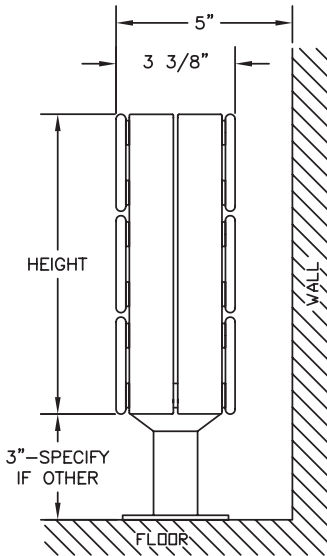
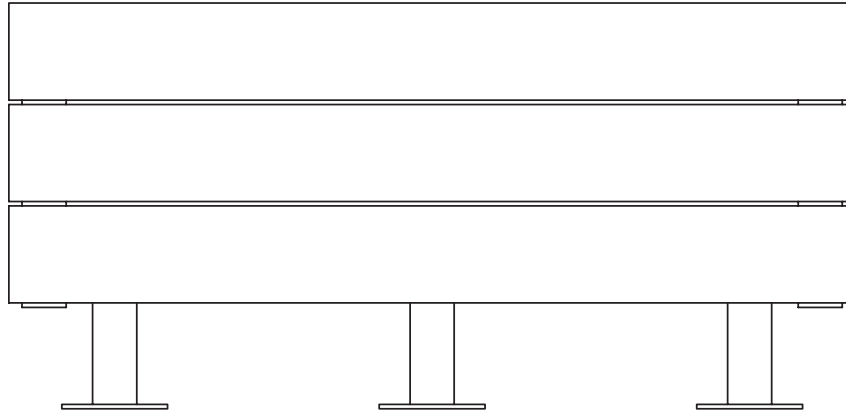

FREE STANDING FLOOR MOUNT FOR "PR2" AND "PR2F" UNITS

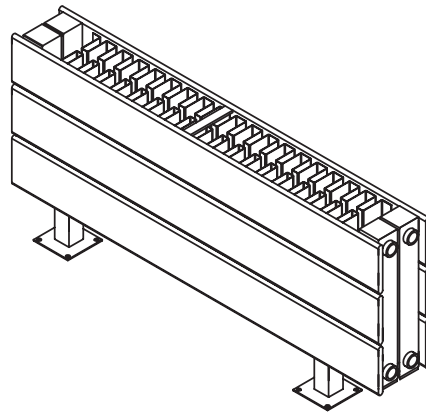

PANEL LENGTH	QTY. OF BRACKETS
24" - 60"	2 PCS
62" - 138"	3 PCS
140" - 192"	4 PCS

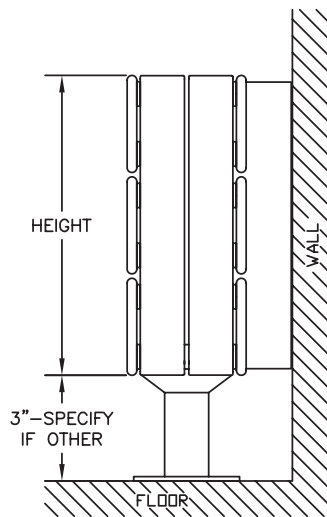

FREE STANDING FLOOR MOUNT FOR "PR3F" UNITS

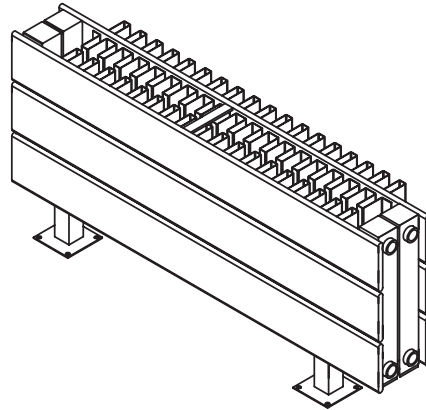

PANEL MODEL	HEIGHT
PR2-1, PR2F-1, PR3F-1	2-3/4"
PR2-2, PR2F-2, PR3F-2	5-3/4"
PR2-3, PR2F-3, PR3F-3	8-5/8"
PR2-4, PR2F-4, PR3F-4	11-1/2"

ONLY AVAILABLE UP TO 4 TUBES TALL

CAT-75589B

STANDARD PIPING CONNECTION LOCATIONS

PR2, PR2F, PR3F PIPING OPTIONS

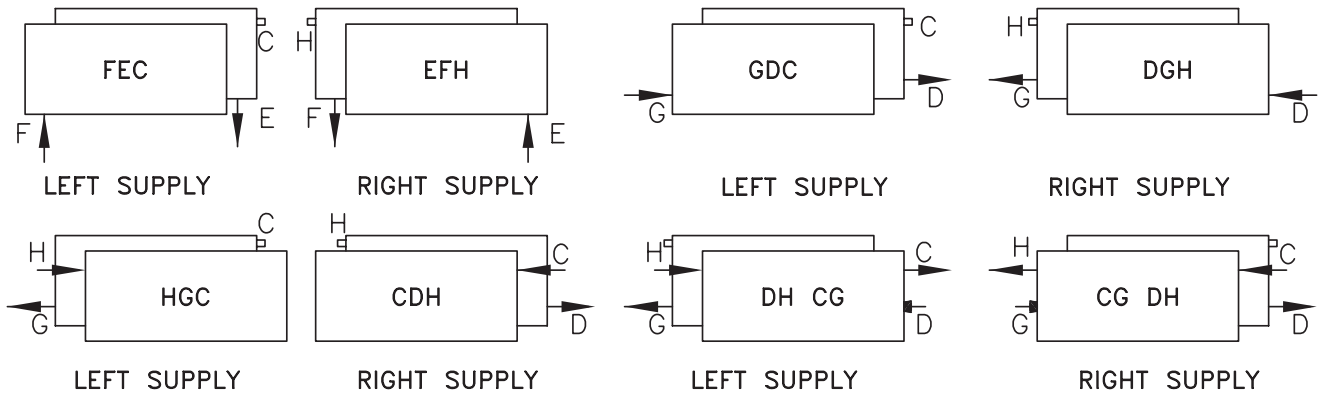

OPPOSITE END SERIES

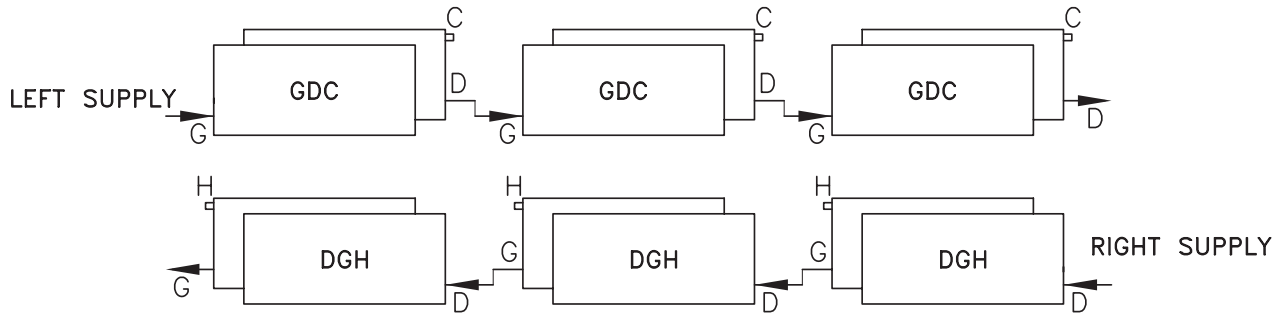

- NOTES:
- VENT ON EACH PANEL
 - CAN ELIMINATE COSTLY RISERS
 - LOWER PD THAN SAME END SERIES
 - UP TO 7 RADIATORS (100 FT) IN SERIES OPPOSITE END
 - EXPANSION COMPENSATION PIPING TO BE PROVIDED BY OTHERS

SAME END SERIES

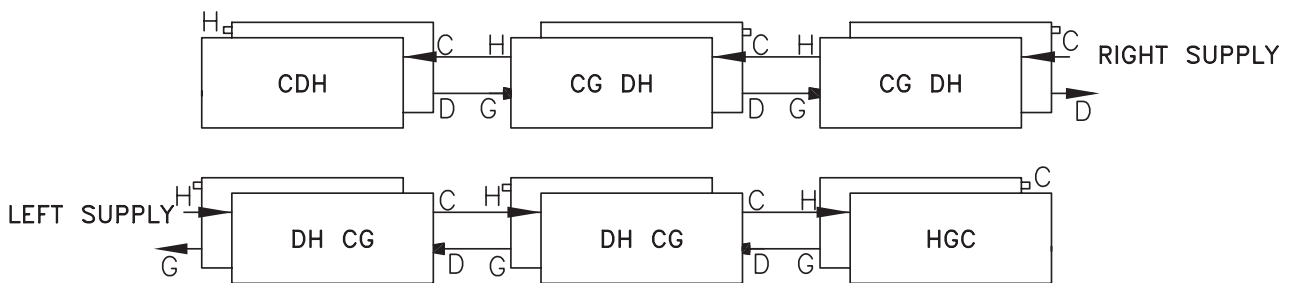

- NOTES:
- SAME AWT OVER THE ENTIRE SAME END SERIES
 - CAN ELIMINATE COSTLY RISERS
 - HIGHER PD THAN OPPOSITE END SERIES
 - NO MORE THAN 3 RADIATORS IN SERIES SAME END
 - EXPANSION COMPENSATION PIPING TO BE PROVIDED BY OTHERS

Model PR2

PANEL RADIATOR SPECIFICATIONS

Specifications

Provide steel double panel radiators of the lengths and in locations as indicated, and of capacities, style, and having accessories as scheduled. The double heating panel radiation shall be of one-piece all-welded steel construction, consisting of a pair of flattened water tube panels welded to headers at each end. The radiator may include an optional integral heavy gauge all-welded perforated top grille, when specified.

All radiator header pipes are square 0.109" minimum wall thickness. The headers shall include all necessary inlet, outlet and vent connections as required. Standard connection sizes are ½" NPT tapered thread for supply and return piping, and 1/8" for the vent connection. Internal baffling is provided where required for proper water flow. Optional 29, ¾" NPT connections are available at an additional cost, when specified.

The radiant heating panels shall be available in lengths from 2'-0" to 16'-0" in two inch even increments without the need for splicing. The panel radiation shall be capable of being mounted to typical stud wall construction without additional blocking or strapping. Appropriate wall mounting brackets shall be provided with the radiation. Optional floor mounting pedestal brackets (for panels up to 4 tubes high) may be provided at an additional cost when specified. Panel radiation expansion shall not exceed 1/64" per foot of radiation at 215°F. The installer shall provide adequate expansion compensation for each radiator.

Pressure Ratings:

Pressure ratings for the radiation shall be as follows:

LOW (Standard)- .048" minimum wall thickness. Working pressure 56-PSI maximum, Test Pressure-74 PSI maximum

OR

MEDIUM (Optional)- .058" minimum wall thickness. Working pressure 85-PSI maximum, Test Pressure-110 PSI maximum

OR

HIGH (Optional)- .078" minimum wall thickness. Working pressure 128-PSI maximum, Test Pressure 184 PSI maximum

Finishes:

The panel radiation shall be cleaned and phosphatized in preparation for the powder coat finish. The radiation is then finish painted with a gloss powder coat finish, for a total paint thickness of 2-3 mils (0.002" - 0.003"). The color shall be selected from Sterling's standard commercial colors. Optional custom colors shall be available at and additional cost.

Warranty:

A 5-Year Limited Warranty covers all Sterling panel radiators.

Options:

Dual header panel radiators (up to 4 tubes tall) may be provided with floor-mounted pedestal brackets at an additional cost when specified. Ribbed pipe cover trims (up to 4 tubes high), finished to match the radiators shall be provided at an additional cost when specified.

Optional integral heavy gauge all-welded perforated top grille is available at an additional cost, when specified.